

# PCB and LCD Testing Guide

This document will guide you on how to determine a fault with the PCB and LCD of the ceiling lift. Follow the steps below to determine if the PCB and LCD are functioning correctly.

The diagram below shows each connection port found on the PCB and what component plugs into each port. Ensure that each port is plugged in (where applicable).

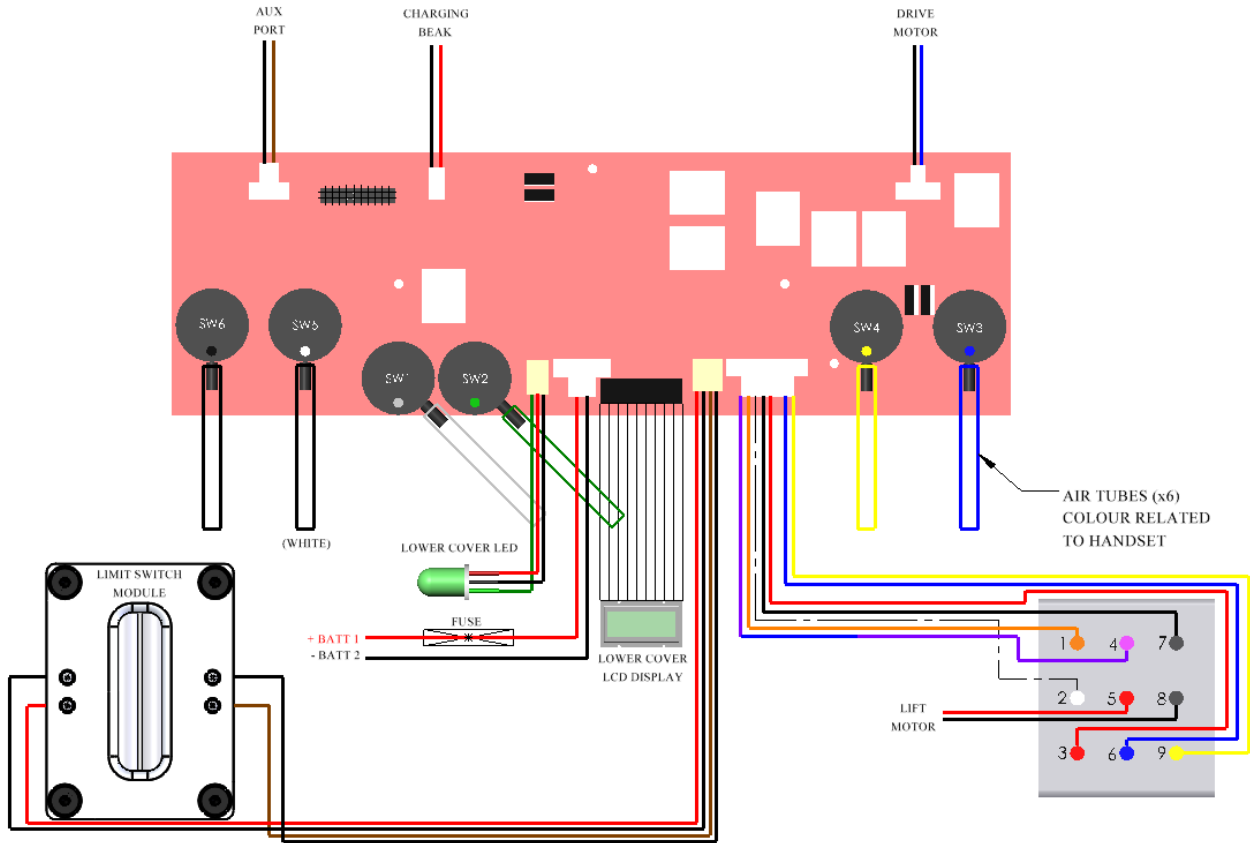

Each of the below troubleshooting guides requires a multi-meter to test power inputs and outputs from the board. Prepare the multi-meter by setting it to read DC volts, the red lead (positive) should be plugged into the voltage port, and the black lead (negative) should be plugged into the COM port. The display screen should show a reading of 0.0 volts.



# Is the LCD receiving power?

## Step 1

Determine the location of the LCD port, this is located at the bottom centre of the board, to the right of the main power port.

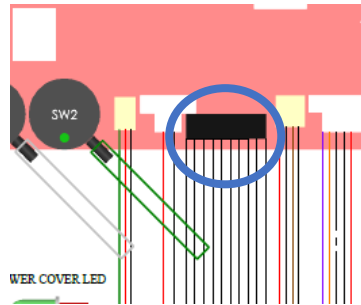

## Step 2

Ensure that the batteries are charged, the LED will flash orange while charging, if unsure of battery status, allow the batteries to charge for at least 20 minutes for sufficient power prior to testing.

## Step 3

Ensure the main power lead (battery lead) is plugged into the PCB.

## Step 4

Disconnect the LCD cable from the port.

## Step 5

To determine if the voltage is running through the port. Touch the black (negative) lead onto the **pin 1**, and the red (positive) lead onto **pin 2**. (See image for reference). This should display between **4.5 and 5v**.

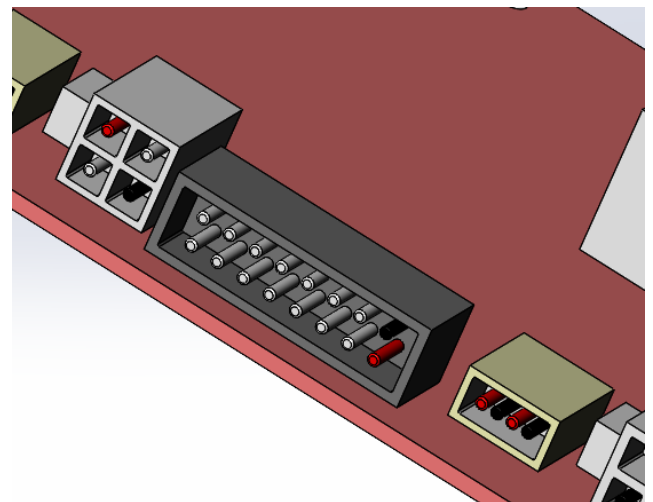
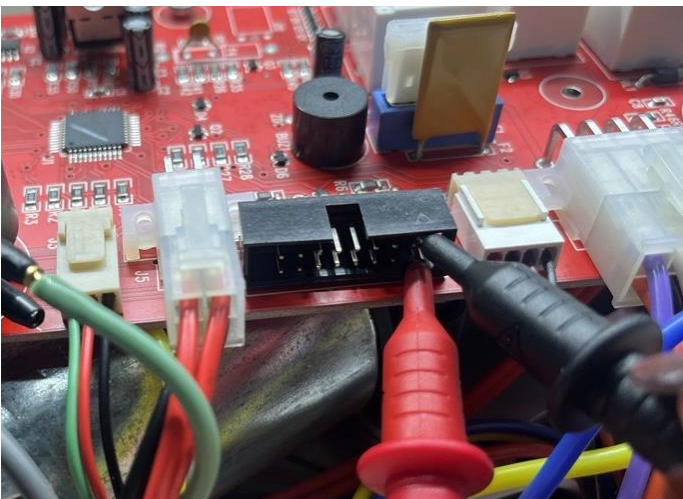

If the LCD port is not receiving at least **4.5v**, then there is a fault in the board. The board must be replaced.

If the LCD port is receiving the correct voltage, then there is a fault with the LCD. The LCD assembly must be replaced.

## Test Complete