

PCB and Drive Motor Testing Guide

This document will guide you on how to determine a fault with the PCB and drive (traverse) motor of the ceiling lift. Follow the steps below to determine if the PCB and drive motor are functioning correctly.

The diagram below shows each connection port found on the PCB and what component plugs into each port. Ensure that each port is plugged in (where applicable).

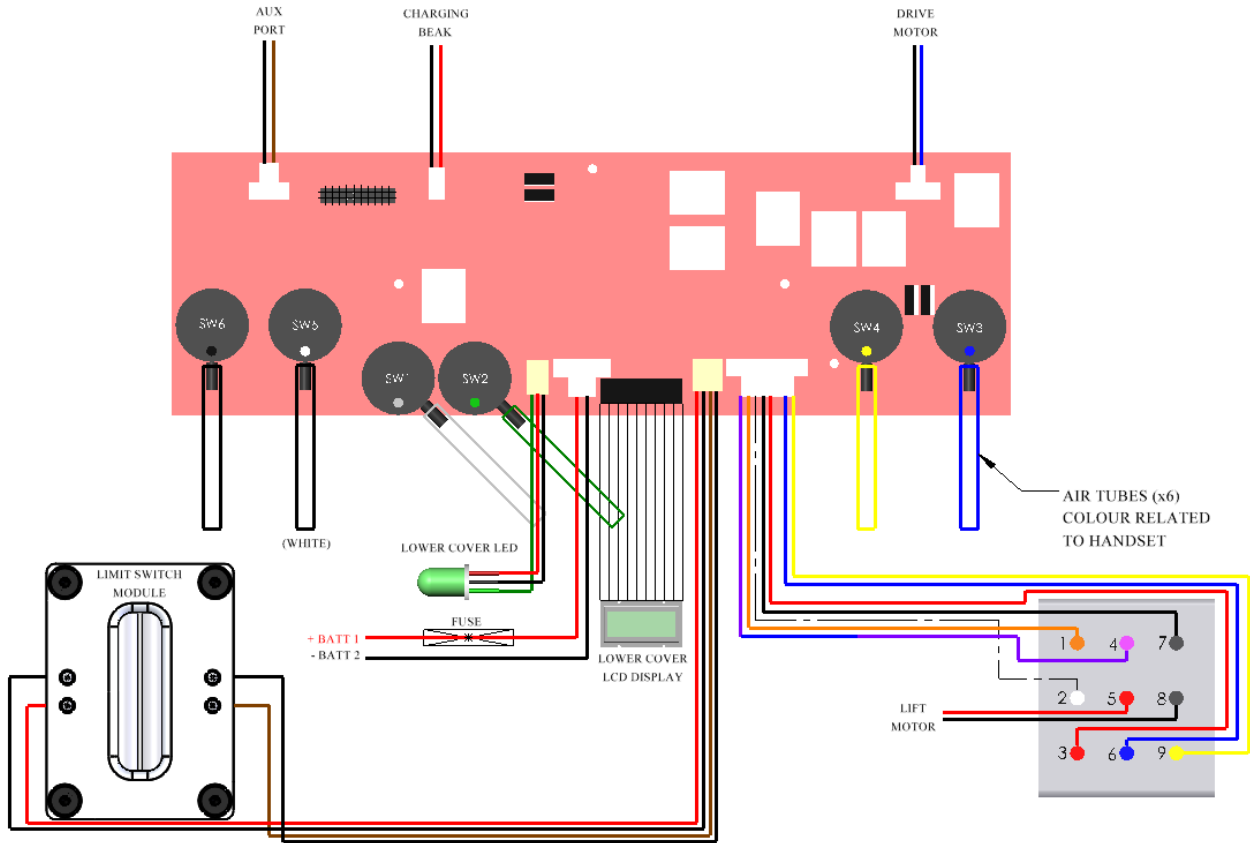

Each of the below troubleshooting guides requires a multi-meter to test power inputs and outputs from the board. Prepare the multi-meter by setting it to read DC volts, the red lead (positive) should be plugged into the voltage port, and the black lead (negative) should be plugged into the COM port. The display screen should show a reading of 0.0 volts.



Is the drive motor receiving power?

Step 1

Determine the location of the drive motor port, this is located at the top right side of the board.

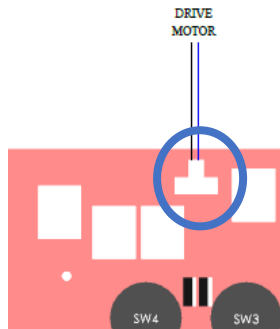

Step 2

Ensure that the batteries are charged, the LCD display will show the current battery status. For best results, fully charge the batteries prior to testing.

Step 3

Disconnect the drive motor cable from the port.

Step 4

To determine if the voltage is running through the port. Touch the black (negative) lead onto the black wire terminal (bottom terminal), and the red (positive) lead onto the blue wire terminal (top terminal). (See image for reference). This should display between **18 and 26v**.

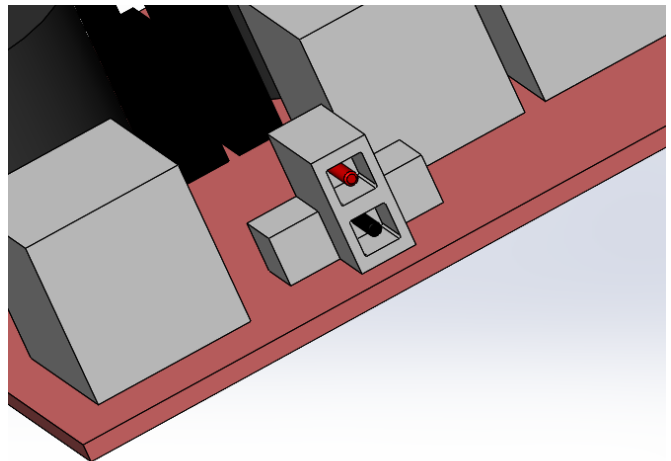
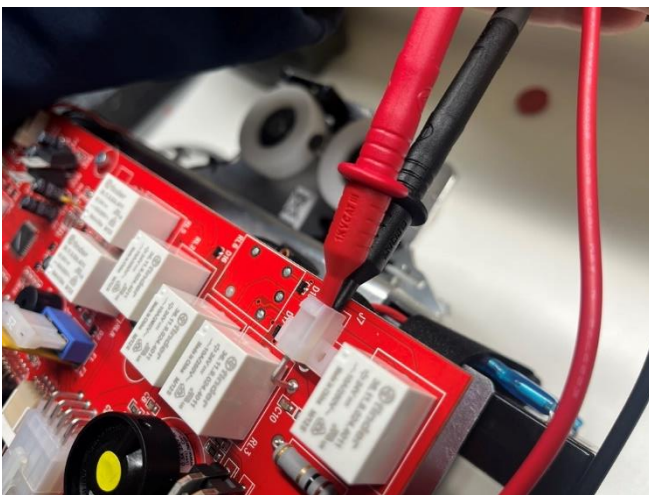

If the drive motor port is not receiving at least **18v**, then there is a fault in the board. The board must be replaced.

If the drive motor port is receiving the correct voltage, then there is a fault with the drive motor. The drive motor must be replaced.

Test Complete

Is there an air leak in the system?

Step 1

Determine the location of the air switches and the air tubes attached, SW1 and SW2 are for the up and down function, SW3 and SW4 are for the traversing, (only applicable to powered traverse ceiling lifts) and SW5 and SW6 are for the powered auxiliary ceiling lifts, where it interacts with a powered turntable or powered h-system (only applicable to powered auxiliary ceiling lifts). The air switches are located at the bottom of the PCB.

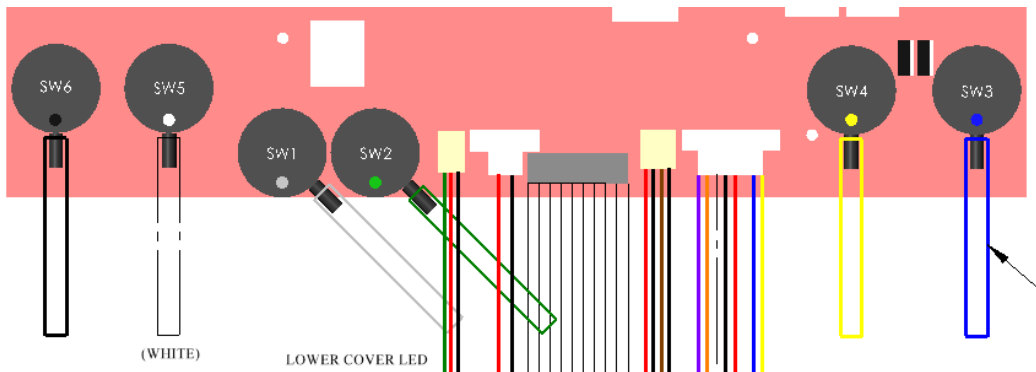

Step 2

Ensure that the batteries are charged, if unsure on battery status, allow the batteries to charge for at least 20 minutes for sufficient power prior to testing.

Step 4

Inspect the length of the air tubes from their connection at the PCB to the connection at the grommet, be observant for any disconnections or split tubes. If damaged, replace the air tubes assembly (with grommet)

Step 5

Perform a simple test to determine if there is any air leak in the system. To do this, disconnect the air tubes from the PCB and connect the handset to the ceiling lift via the grommet. Individually press all the buttons on the handset, after pressing the button, place your thumb over the related air tube (grey from up etc.) and release the handset button. If the system is secure the button will remain depressed. If the button releases (even if it's slow), there is an air leak in the system. Repeat this for each air tube. If any of the air tubes fail the test, replace the air tube and grommet assembly. (Ensure this test has already been done for the handset system, see 'handset testing guide' if not).

If the air tubes pass the test, there is a fault with the PCB air switches and the PCB must be replaced.

Test Complete